

CONFIGURATION FROM 5.5 KW
WITH MOTOR ADAPTER

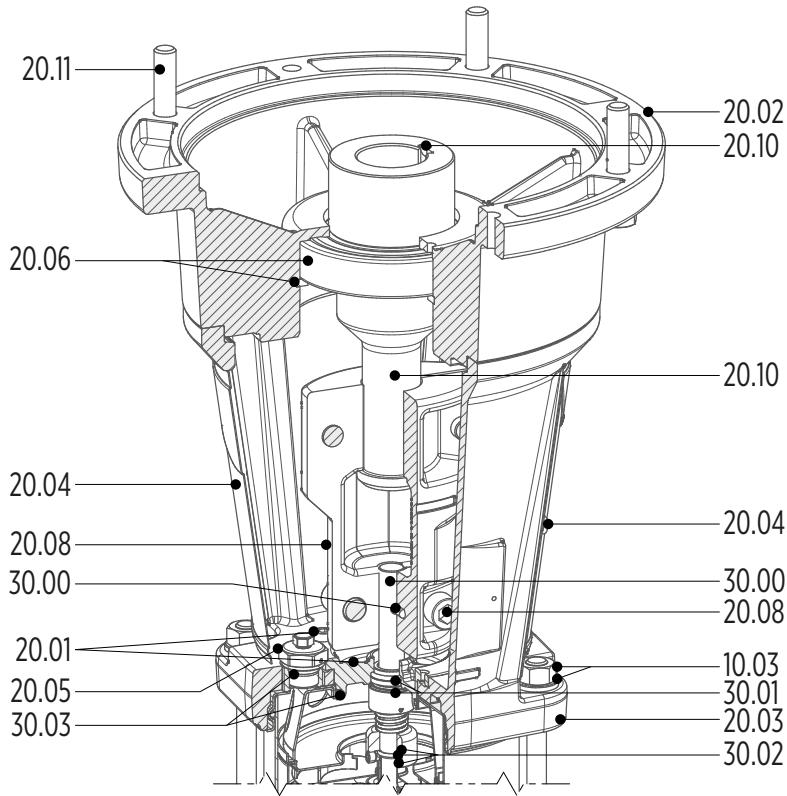

CONFIGURATION UP TO 4 KW

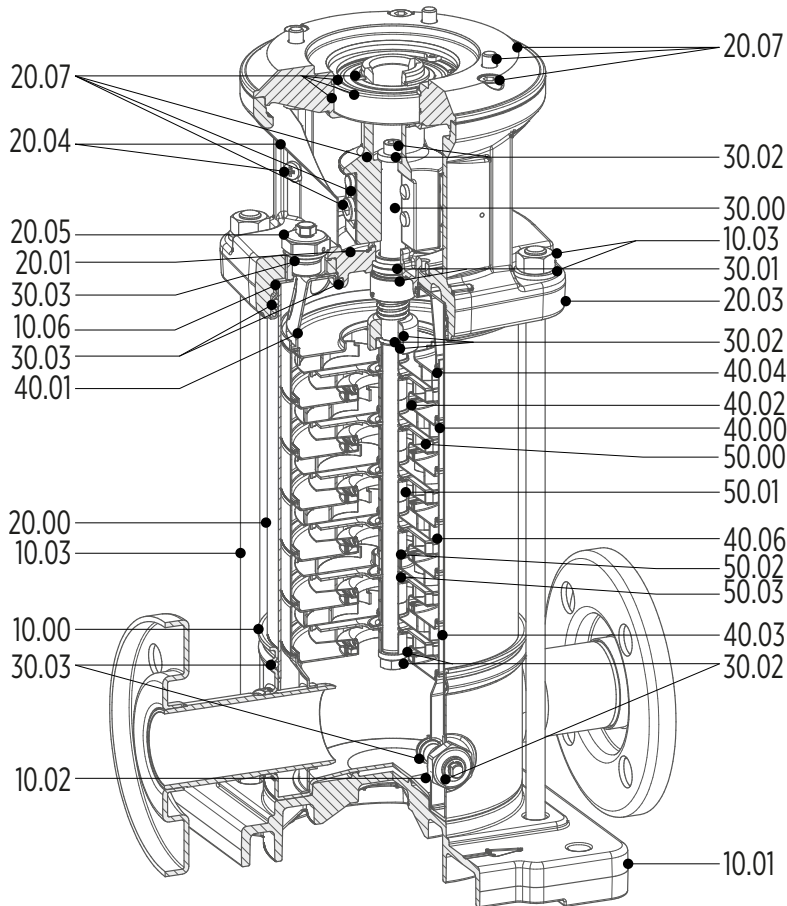

PARTS IN CONTACT WITH LIQUID

Ref. No	Parts description	Material	Reference standard			
			I version		N version	
			ASTM	DIN/EN	ASTM	DIN/EN
10.00	Pump casing	Stainless Steel	AISI 304	1.4301	AISI 316L	1.4404
10.02	Draining plug	Stainless Steel	AISI 304	1.4301	AISI 316	1.4401
10.06	Upper flange	Stainless Steel	AISI 304	1.4301	AISI 316L	1.4404
20.00	Outer case	Stainless Steel	AISI 304	1.4301	AISI 316L	1.4404
20.01	Mechanical seal housing	Stainless Steel	CF 8 / AISI 304	1.4308	CF 8M / AISI 316	1.4408
20.05	Filling plug	Stainless Steel	AISI 304	1.4301	AISI 316	1.4401
30.00	Pump shaft	Stainless Steel	AISI 304	1.4301	AISI 316L	1.4404
30.01	Kit mechanical seal	Stainless steel, Carbon graphite, Silicon Carbide (SiC), EPDM	-	-	-	-
30.02	Mechanical seal fastening kit	Stainless Steel	AISI 304	1.4301	AISI 316	1.4401
30.03	Kit O-rings	EPDM	-	-	-	-
40.00	Stage housing and diffuser	Stainless Steel	AISI 304	1.4301	AISI 316L	1.4404
40.01	Stage Centering outlet	Stainless Steel	AISI 304	1.4301	AISI 316L	1.4404
40.02	Floating neck ring	Stainless steel, PPS	AISI 304	1.4301	AISI 316	1.4401
40.03	Initial stage housing	Stainless Steel	AISI 304	1.4301	AISI 316L	1.4404
40.04	Last Stage with diffuser	Stainless Steel	AISI 304	1.4301	AISI 316L	1.4404
40.06	Stage housing and diffuser with bearing	Stainless Steel, Tungsten carbide (WC)	AISI 304	1.4301	AISI 316	1.4401
50.00	Impeller	Stainless Steel	AISI 304	1.4301	AISI 316L	1.4404
50.01	Impeller spacer	Stainless Steel	AISI 304	1.4301	AISI 316L	1.4404
50.02	Intermediary sleeve	Tungsten Carbide (WC)	-	-	-	-
50.03	Intermediary sleeve spacer	Stainless Steel	AISI 304	1.4301	AISI 316L	1.4404

SPARE PARTS LIST

Ref. No	Parts description
10.00	Pump casing
10.01	Pump base
10.02	Draining plug
10.03	Tie bolts, washers and nuts
10.06	Upper flange
20.00	Outer case
20.01	Mechanical seal housing
20.02	Motor flange
20.03	Motor bracket
20.04	Coupling guard
20.05	Filling plug
20.06	Kit bearings
20.07	Motor flange, coupling and bearing kit
20.08	Coupling
20.10	Motor shaft adapter

Ref. No	Parts description
20.11	Lifting eyelets and bolts
30.00	Pump shaft
30.01	Kit mechanical seal
30.02	Mechanical seal fastening kit
30.03	Kit O-rings
40.00	Stage housing and diffuser
40.01	Stage Centering outlet
40.02	Floating neck ring
40.03	Initial stage housing
40.04	Last Stage with diffuser
40.06	Stage housing and diffuser with bearing
50.00	Impeller
50.01	Impeller spacer
50.02	Intermediate sleeve
50.03	Intermediate sleeve spacer